

## DI<sup>900</sup> mailing checklist:

### Productivity

- ✓ Load-on-the-fly - no need to stop to reload feeders
- ✓ 'Linked feeders' - jobs can be run quickly without reloading
- ✓ High capacity sheet feeders provide increased capacity for multi-page jobs
- ✓ A range of stacker options is available to accommodate high volume output
- ✓ Connectivity - the DI<sup>900</sup> connects to Pitney Bowes DM Series mailing machines for in-line production and increased productivity

### Ease of Use

- ✓ PacPilot™ colour User Interface - applications are easy to set-up, edit and modify
- ✓ SwiftStart™ - intelligent job processing for the casual user
- ✓ Speedy problem resolution with clear, precise guidance displayed on the screen
- ✓ Smart nip folding element - automatically adjusts the folder settings for different jobs

### Flexibility

- ✓ Unique automatic envelope aligner - adjusts the envelope position relative to the mail pieces to ensure accurate, error free inserting
- ✓ Flexible tower feeder allows any combination of different sized sheets and inserts
- ✓ Pre-fold accumulator - to enhance the mail piece presentation
- ✓ Wide variety of materials accepted to meet the creative requirements of today's mailing applications

### Security and Integrity

- ✓ Trial piece to confirm accuracy before the job is run
- ✓ Double Document Detection - ensures every mail piece is accurate
- ✓ Latest scanning technology to add value to 'intelligent' mailing applications

## The FastPac™ DI<sup>900</sup> Inserting System can be built to your specific needs

### Entry level DI<sup>900</sup>

- » Includes four-feeder tower
- » Max. dimensions Length 1905mm, Height 787mm, Depth 579mm, Weight 148.4kg
- » Up to 4300 pieces an hour

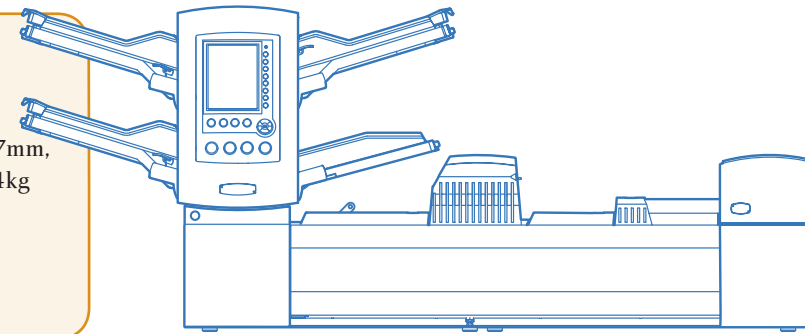

### Fully configured DI<sup>900</sup>

- » Includes four-feeder tower and two high capacity sheet feeders
- » Max. dimensions: Length 3379mm, Height 851mm, Depth 579mm, Weight 219.5kg
- » Up to 4300 pieces an hour

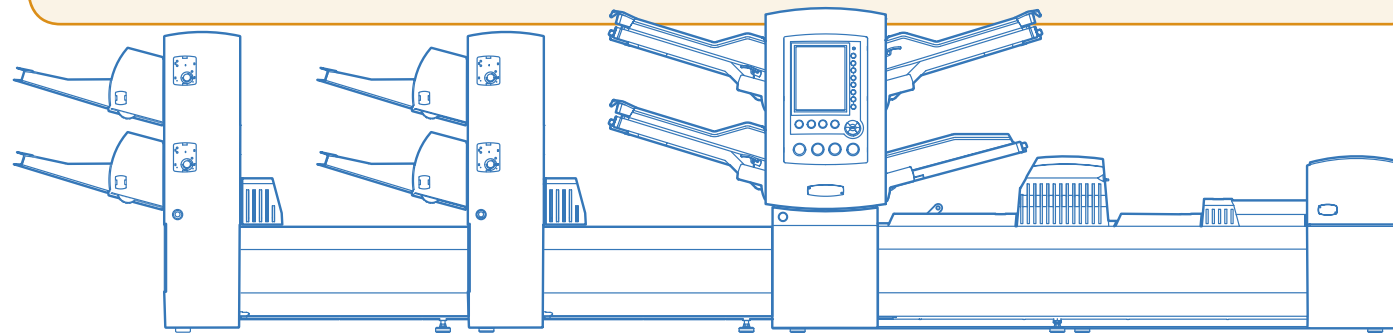

*Pitney Bowes expertise covers the full spectrum of inserting requirements from Automated Document Factory environments to machines which will fit comfortably on your desktop. The DI<sup>900</sup> combines the power of high level inserting machines with the ease of use found in desktop machines.*



*Engineering the flow of communication™*

Pitney Bowes  
Elizabeth Way, Harlow  
Essex CM19 5BD  
Telephone: 08705 252525  
Facsimile: 08705 449450  
www.pitneybowes.co.uk

© 2005 Pitney Bowes Ltd. All rights reserved.

*Pitney Bowes is the world's leading provider of integrated mail and document management systems, services and solutions. The \$5.1 billion company helps organisations of all sizes engineer the flow of communication to reduce costs and increase impact, and enhance customer relationships. The company's 80-plus years of technological leadership has produced many major innovations in the mailing industry and more than 3,500 active patents with applications in a variety of markets, including printing, shipping, encryption, and financial services.*

CE Pitney Bowes certifies that the FastPac™ DI<sup>900</sup> complies with the requirements of the Low Voltage Directive 73/23/EEC and the EMC Directive 89/336/EEC.

AD481UK (09/05)



# FastPac™ DI<sup>900</sup> Inserting System

Fast-track to a higher level



## Fast-track to a higher level...

Mail is the single most dependable and consistent link to your customers. You want to make the most of it by harnessing the full power of your mailing operation. Add personalised inserts to your transactional mail. Use sophisticated direct marketing campaigns to target specific customer segments.

You're doing larger and more complex mailings to reach more customers and grow your business. Maybe the volume and complexity of your mail has outgrown your current system's capacity. Perhaps you're spending too much money outsourcing jobs in order to meet deadlines. You need a system that can take your mailing operation to a higher level.

### Drive professional customer communications

The FastPac™ DI<sup>900</sup> Inserting system is designed to handle a wide range of mailings quickly and accurately, even when you're doing complex applications such as multi-page statements, promotional mail with multiple inserts or credit card mailings.

Not only does the DI<sup>900</sup> make your customer communications more efficient, it's versatile enough to serve many departments – marketing, accounting, employee benefits – that often have a wide range of mailing needs.

The DI<sup>900</sup> works seamlessly with Pitney Bowes document management software so you can be confident that each envelope contains the correct contents. And it's simple enough for anyone to use.



## ...of innovation

- » With SureTrac™ software it's easy to create documents that can tailor the contents of each mail pack to the recipient, by adding BCR or OMR marks. It's also straightforward to create your own documents, reducing reliance on expensive pre-printed forms.
- » The PacPilot™ colour graphical user interface provides a higher level of ease of use. You are no longer reliant on a few trained operators or lengthy tutorials to get your mailings done.
- » The PacPilot™ display uses intuitive menus and photographs to guide even inexperienced users through the steps of selecting jobs, loading materials, and creating new jobs or editing existing ones.



The PacPilot™ user interface is just one of the DI<sup>900</sup>'s several innovative features.

- » The unique automatic envelope aligner scans the position of the envelope just prior to insertion, and makes precise adjustments if required, improving quality and reliability.
- » The electronic 'smart nip' folder sets up the folder automatically for different jobs, and allows the fold settings to be changed instantaneously within jobs. This means that a wider range of inserts can be included in the same mailing.

*Focussed on customer processes, this complete solution brings features usually seen only for very high production mailers.*

### Software driven intelligence

The DI<sup>900</sup> enables you to manage your mailing process in an intelligent way. Software available with the DI<sup>900</sup> makes document creation and processing simple. You can create truly personalised mail pieces with marketing messages and other content tailored for each recipient. You can also generate detailed records of each mailing job, making it easy to confirm exactly what was mailed to whom and regenerate individual items if required.

## ...of flexibility

The FastPac™ DI<sup>900</sup> offers a higher level of flexibility in the range of applications that can be run.



Flexible Tower Feeders

Flexible tower feeders have interchangeable trays allowing for any combination of different sized sheets and inserts. This means you can run a wide range of jobs with fewer feeders, which combined with the tower configuration, gives a smaller footprint. Feeders can be linked to increase running time.



High capacity sheet feeders

The optional high capacity sheet feeder modules are easy to load and allow for a total of 1000 sheets per tray. They can be used independently or linked for even greater productivity. They offer the ultimate in added production and capacity for multi-page jobs.



Industry Innovation



## Meeting your requirements ...

- **A safe and reliable partner** - Pitney Bowes is a Fortune 500 company with annual revenues of \$5.1 billion and over 2 million customers in 130 countries. We shape the future of mail and document management by investing \$100 million in R&D each year.
- **Flexible finance** - The right mailing solution is essential to the effective operation of today's business. Our customers demand flexible solutions for future growth, being able to enhance, add to, modify and reconfigure their systems... being flexible is all in a day's work.
  - We offer an imaginative range of flexible solutions - so make the smart business decision and lease your mailing system (equipment) through Pitney Bowes Financial Solutions Europe.
    - Acquire new equipment quickly and easily.
    - Keep pace with new technology.
    - Improve your cash flow and free up alternative lines of credit.
    - Update your equipment as your business needs change.
  - **ValueMax** - an innovative equipment protection plan that provides you with a real, 'no risk' alternative to traditional equipment insurance. Here's why:
    - No third party involvement.
    - Immediate response in the event of a claim.
    - No minimum loss size.
    - Multi-risk cover.
    - No excess.
    - New for old replacement policy.
  - **Satisfaction guaranteed** - Pitney Bowes views all forms of service and support as a long-term commitment and part of a lifelong relationship with customers. We aren't satisfied unless you're satisfied. This isn't just empty words, we can back this up by offering a 5 year Customer Satisfaction Guarantee.
  - **Flexible service** - Pitney Bowes offers packaged or tailored service in response to the differing needs of businesses. So you can choose the appropriate levels of service cover according to your own assessment of 'criticality'.
  - **Superb support** - Our Customer Service Representatives are highly trained and supported by a new multi-media contact centre and computerised service management system. All our systems are integrated so that equipment inventories, service history and current requirements can be seen by all, helping us to allocate the right CSR for fast resolution.
    - In addition - our National Service Centre provides a front line response service unique to Pitney Bowes. Approximately 40% of all calls are resolved over the phone reducing downtime significantly. Your equipment is back up in minutes.
  - **Quality nationwide service** - Our network is staffed with over 300 trained personnel operating from 7 service hubs. Our commitment to training and development has been recognised by the Investors in People Award and our quality service processes are independently audited by BSI to maintain our ISO9001 accreditation.